

*Journal of the
American Musical
Instrument Society*

VOLUME XLIV • 2018



Copyright by the [American Musical Instrument Society](#).
Content may be used in accordance with the principles of fair
use under [Section 107 of the United States Copyright Act](#).
Content may not be reproduced for commercial purposes.

Charles Jean-Baptiste Soualle and the Saxophone

STEPHEN COTTRELL

Charles Jean-Baptiste Soualle is an enigmatic figure in the history of nineteenth-century music. It is sometimes recognized that he achieved distinction as a clarinetist and saxophonist in Paris and London in the late 1840s and early 1850s, before undertaking a world tour that was prodigious by the standards of the time; and that he adopted the orientalist stage persona of “Ali Ben Sou Alle,” performing on a modified version of the saxophone which, in keeping with his stage act, he renamed as a “turkophone.” But details beyond these bare facts are often elusive.

This paper explores Soualle’s global concertizing in the mid-nineteenth century and endeavors to set out an authoritative version of a story that makes tantalizing appearances elsewhere.¹ It considers Soualle’s contribution not only to the saxophone’s dissemination and repertory in the nineteenth-century, but also, because of several modifications to the instrument that he protected by patent in 1860, to its technical development. In short, the paper seeks to position Soualle as a rather more important figure in saxophone history than has previously been accepted.

The World Tour of Charles Jean-Baptiste Soualle 1824–1853: Paris and London

Charles Jean-Baptiste Soualle was born in Arras, northern France, on 16 July 1824.² After attending his local conservatoire for several years, he

1. See, for example: Fabien Chouraki, “Ali-Ben-Sou-Alle: Un Mystérieux Saxophoniste du 19^e Siècle,” *Bulletin de l’Association des Saxophonistes de France* 47 (1995). Michael Segell, *The Devil’s Horn: The Story of the Saxophone, from Noisy Novelty to King of Cool* (New York: Farrar, Straus and Giroux, 2005), 24. Albert R. Rice, “Making and Improving the Nineteenth-Century Saxophone,” *Journal of the American Instrument Society* 35 (2010), 91. Antonino Mollica, “The ‘Exotic’ Saxophone in the 19th and 20th Centuries,” in *A History of the Saxophone through the Methods Published in France: 1846–1942*, ed. Pascal Terrien (Sampzon, France: Editions Delatour, 2015). Becky L. Steltzner, “The History of the Clarinet in South Africa” (University of Cape Town, 2016), 149–64.

2. Perhaps because Soualle spent much of his life promoting his alter ego Ali Ben Sou Alle, his proper name is often confused. He is not “Charles Valentin” as is sometimes stated (e.g. on the home page of the modern publisher *Musik Fabrik*), nor

was accepted into Klosé's clarinet class at the Paris Conservatoire, achieving a second prize in 1842 before graduating with the first prize in 1844.³ He then appears to have spent time as director of music in a marine guard band in Senegal, at that time a French colony.⁴ It was perhaps this posting that gave Soualle a taste for international travel, which he was to pursue with some dedication over the next two decades. At some point he returned to Paris to take up a position as clarinetist in the orchestra of the Opéra Comique. After the 1848 uprising that led to the overthrow of King Louis Philippe, Soualle travelled to England, becoming first clarinet of the Queen's Theatre in London. Here he met the impresario Louis Jullien, and was persuaded to join Jullien for some of the latter's popular musical extravaganzas, his promenade concerts. Thus Soualle appeared in 1850 as a performer in one of Jullien's monster quadrilles (requiring 207 instrumentalists), playing an instrument described as a "corno musa," accompanied by a harp.⁵ Newspaper descriptions of the time make it clear that this "corno musa" was undoubtedly a saxophone, although Jullien continued to use the neologism on several later occasions: the *Manchester Guardian* was still using the term two years later, as was the *New York Times* in 1853.⁶ Soualle's 1850 performances would have been one of the earliest appearances of the saxophone in England, and his initial engagement by Jullien was sufficiently noteworthy to have

"Augustin Edouard" as listed in a British naturalization request submitted in 1863 (see text). Nor should he be confused with Alexandre Soualle, a manufacturer of music boxes and similar, who was also working in Paris in the 1850s and '60s. The record of Soualle's birth notes his name as "Charles jeanbaptiste" but I have employed here the more modern orthography of "Jean-Baptiste." A copy of his birth registration may be consulted online at <http://www.archivespasdecalais.fr/Chercher-dans-les-archives/Archives-en-ligne/Etat-civil/Tables-decennales> (search for the list of births in 1824, then use either reference 3 E 4 or simply select the volume covering Arras. The entry can be found on page 150 of the search interface, although it is marked as page 303 on the text itself).

3. Théodore de Lassabathie, *Histoire Du Conservatoire Impérial de Musique et de Déclamation* (Paris: Michel Lévy Frères, 1860), 179.

4. The details relating to this period of Soualle's life are hazier than most, but Soualle referred to this time in Senegal in a brief self-portrait published in *Le Figaro* in 1875, dealt with in more detail below.

5. This was a pun on the word "cornamusa" (cornemuse in English) which was applied to a type of bagpipe common in rural France at this time. Soualle's performance was widely advertised in the contemporary English press, e.g., *The Morning Chronicle*, 18 November 1850, 4.

6. See F. Geoffrey Rendall, "A Short Account of the Clarinet in England during the Eighteenth and Nineteenth Centuries," *Proceedings of the Musical Association* 68 (1941-42), 79, and *New York Times*, 21 December 1853, 1.

been recorded in Paris by *La Revue et Gazette Musicale de Paris* (RGMP) that same year.⁷

In February 1851 Soualle was back in Paris, giving a concert on the saxophone at the *Union musicale*. His performance elicited several favorable reviews, suggesting that the standards he achieved on the instrument were commensurate with those prevailing on other woodwind instruments. Berlioz, writing some two months later in the *Journal des débats*, observed that Soualle, “recently returned from London, produced a great sensation in making heard for the first time in Paris, with all its advantages, the saxophone, masterpiece of Sax.”⁸ Henri Blanchard, writing in the *RGMP*, similarly noted that although the velvety, suave tone of the saxophone was well known, Soualle had demonstrated that the instrument was equally capable of detached notes and fast, complicated movements: “A clarinet, a flute would not have played better. We don’t doubt that after this decisive test, skilled virtuosos will hasten to adopt an instrument that promises to produce new effects.”⁹

In later life Soualle recalled that on his return to Paris in 1851 he played the saxophone in a performance of Félicien David’s oratorio *Le désert*, a work that was premiered in 1844 but repeated regularly thereafter in Paris and beyond because of its popularity. There is no independent verification of Soualle’s involvement, nor is there a saxophone part in David’s original score. However, the score does call for an ophicleide, which largely reinforces the third trombone part. Since the saxophone was originally conceived as a replacement for the ophicleide, and in its earliest incarnations was closely modeled on this large keyed bugle, it is possible that Soualle played a bass version of the saxophone in some of these performances. But the significance of Soualle’s recollection lies not so much in its accuracy or otherwise, but more in the fact that he sought to associate himself with a work that was decidedly orientalist in nature, which David had been inspired to compose after visits to Egypt and the Middle East.¹⁰ If Soualle’s assertion is true, this may have marked the beginning of his own extensive commitment to musical orientalism. The development of such interests on Soualle’s part is perhaps unremarkable given that, as Edward Said puts it, “for something more than

7. *Revue et Gazette Musical de Paris*, 22 December 1850, 422; henceforth *RGMP*.

8. *Journal des débats*, 13 April 1851, 2.

9. *RGMP*, 23 February 1851, 67.

10. For more on the background to *Le Désert* see Peter Gradenwitz, “Félicien David (1810–1876) and French Romantic Orientalism,” *The Musical Quarterly* 62, no. 4 (1976).

the first half of the nineteenth century Paris was the capital of the Orientalist world.¹¹

In November 1851 Soualle was back in London with Jullien for the autumn season, participating in Jullien's own supposedly orientalist fantasy, his *Indian Quadrille*. Like *Le désert*, this sought to connote for its large audience distant lands and peoples and, so the concert program assured, "the novelty of the instruments of the native Indians used in their dances, festivals, sports, wars, rallies and ceremonies. &c." But as *The Illustrated London News* observed, "many of the listeners were rather startled at hearing familiar Scotch melodies, Tyrolean airs, and other well-known acquaintances . . . [Jullien] has of course worked up the subjects after his own fashion, more promenadish than Indianic perhaps, but none the less piquant and quaint."¹² Soualle stayed with Jullien's company through the winter, including for their performances in Dublin in January 1852, in which he was once again advertised as playing the "corno musa" in Jullien's *Aurora Serenade*.¹³ After some concerts given in London in March 1852¹⁴—now unashamedly playing the saxophone—Soualle re-joined Jullien for his autumn series later that year, which was billed as "M. Jullien's last annual series of concerts prior to his departure for America."¹⁵ Here he played alongside Henri Wuille, a renowned Belgian clarinetist whom Jullien had also hired. But in 1853, when Jullien and a group of his star soloists travelled to the United States for his inaugural tour, it was Wuille who accompanied him, not Soualle.¹⁶

1853–55: Australia and New Zealand

By the time Jullien arrived in the United States in August 1853, Soualle had already completed the much longer journey to Australia, landing sometime before mid-June that same year. His migration is easily explained: he was joining the Australian gold rush, a fact that was confirmed on several occasions in later years as well as being evidenced by the titles of some of his compositions, such as the "Goulburn Waltz" and

11. Edward W. Said, *Orientalism* (London: Routledge and Kegan Paul, 1978), 51.

12. *The Illustrated London News*, 16 November 1851, 642.

13. *Freeman's Journal and Daily Commercial Advertiser*, 5 January 1852, 1.

14. See, for example, *The Morning Post*, 4 March 1852, 5.

15. In, for example, the *Daily News*, 26 November 1852, 4.

16. Wuille was booked for this trip primarily as a clarinetist, although he did perform on the saxophone with Jullien and gave the instrument its USA debut during this tour, on 19 December 1853. See Stephen Cottrell, *The Saxophone* (New Haven: Yale University Press, 2012), 116–17.

the “Diggers Polka.”¹⁷ By this time European—especially British—migration to the colonies of New Zealand and Australia was well established, largely driven by this search for gold. One estimate suggests that Australia’s total population nearly quadrupled between 1851 and 1871. The number of immigrants amounted to 370,000 in 1852 alone, and the state of Victoria saw 290,000 British immigrants between 1852 and 1860, with a further 15,000 from other European countries.¹⁸ Such rapid population growth made significant demands on local infrastructure. As the novelist Anthony Trollope later put it, “not only miners came, but also the miners’ wants. Houses were built, and banks were opened—and with the banks, schools and churches. And thus a colony was formed, owing its existence almost as much to those who failed as those who succeeded.”¹⁹ Soualle clearly hoped to be part of the latter category, but like so many others, in terms of gold prospecting, he was part of the former.

In addition to “banks, schools and churches,” these new communities also needed entertainment, and Soualle was just one of many European musicians who made their way to Australia, drawn not only by its auric lure but also in the knowledge that they could fall back on their musical skills to support themselves if needed.²⁰ Perhaps the most financially successful of these was the bassoonist John Winterbottom. Like Soualle, Winterbottom had been part of Jullien’s entourage in the late 1840s, and it is therefore almost certain that they knew each other. Unlike Soualle, Winterbottom quickly established himself as a major concert promoter in Australia, successfully replicating Jullien’s style of promenade concerts, including “Monster Concerts,” for a decade after his arrival sometime in 1851, until he returned to Europe in 1861.²¹ By the time Soualle arrived in mid-1853, therefore, Jullien’s populist admixture of polkas, waltzes, gallops and quadrilles, etc., interspersed with songs

17. Goulburn, a town in New South Wales, played an important role in the 1850s gold rush.

18. Figures taken from <http://www.australia.gov.au/about-australia/australian-story/austn-gold-rush> and <http://www.sbs.com.au/gold/story.php?storyid=49> (retrieved 23 December 2015).

19. George Fetherling, *The Gold Crusades: A Social History of Gold Rushes, 1849–1929* (Toronto: Macmillan, 1988), 49.

20. For more on these migrant European musicians in early colonial Australia, see Graeme Skinner, “Toward a General History of Australian Musical Composition: First National Music 1788–C.1860” (thesis, Sydney Conservatorium of Music, 2011).

21. Skinner (*ibid.*, 318.) suggests that Winterbottom arrived in Australia in 1853, but 1851 appears more plausible. See <http://trove.nla.gov.au/people/680052> (retrieved 23 December 2015).

and occasional extracts from standard orchestral repertoire, was already a familiar cultural event in certain colonial quarters of Australia.

Soualle's first performance was given on Monday 13 June 1853 as part of a concert at the Mechanics' Institute in Melbourne, Victoria, the performance having been advertised over the previous few days.²² Somewhat confusingly, while the short commentary piece in the Melbourne *Argus* on Saturday the 11th heralded the arrival in Australia of "a newly-invented and most remarkable instrument styled the saxophone," the advertisement of the day before had made no reference to the saxophone, describing the instrument instead as a "turkophone." The *Argus*, doubtless having received some swift communication from Soualle over the weekend, was at pains to clarify the situation for its readers in the Monday edition: "We perceive that the saxophone of which we made honorable mention on Saturday is christened for this evening's concert by a new name. M. Soualle, availing himself of the fact of his being of Turkish extraction (literally, we believe, the son of a Turk), to add a little novelty to his entertainment, will appear in the picturesque costume of that country."²³ Soualle had clearly learned a great deal from Jullien in matters of musical novelties, neologisms, and the telling of tall tales to enhance the exotic mystique of musical acts.

Doubtless drawing on his experience of Jullien's *Indian Quadrille*, and possibly also recalling the impression made on him by David's *Le désert*, Soualle's act on his musical travels would henceforth be based around an orientalist stage persona involving exotic costumes and the rebranding of the saxophone as the turkophone (fig. 1). The first three advertisements for his Australian concerts described him as "Ali Ben Soualle," but by Tuesday 14 June, the *Argus*, again probably under instructions from Soualle himself, had modified its orthography to enhance Soualle's mystical qualities and further distance him from his European heritage in his audience's imagination: henceforth Soualle would always be known as "Ali Ben Sou Alle," not only on his travels over the next few years but also on his eventual return to Europe. He pursued this characterization with considerable determination, often travelling under this pseudonym as well as using it to register later patents and businesses.

Soualle's orientalist act, coupled with his obvious abilities as an instrumentalist, appears to have been a successful combination. He gave numerous concerts over the next two years in New South Wales, Tasmania, and New Zealand. Moving in and around the major centers such as

22. *The Argus*, 10 June 1853, 5 and 11 June 1853, 5.

23. *The Argus*, 13 June 1853, 7.



FIGURE 1. A contemporary engraving of Ali Ben Sou Alle by R. G. Hamilton, date unknown. It was used as the cover image of piano variations on Soualle's 'Polka', published in London, c.1864.

Sydney and Melbourne, Hobart and Wellington, he refined both his expertise on the turko/saxophone and honed an act that would be widely repeated over the ensuing years. At times his performance schedule was relatively intense. In December 1854, for example, he gave concerts in Sydney on the 21st, 27th, and 28th of December, before moving on to what was then described as "our principal provincial towns," where he planned to give concerts in Liverpool, Campbelltown, and Camden

on successive evenings the following week, before following this with several concerts in Goulburn.²⁴

Soualle's concertizing around Australia and New Zealand was by no means unique, and he found himself to be one of a small roster of artists who sought to take advantage of the growing communities of migrant Europeans who wished to remain in touch with European musical culture. Miska Hauser, for example, a relatively well-known Austrian violinist, similarly toured extensively between 1853 and 1858, spending time in California (United States), South America, and Australia. Notices about Hauser's concerts are often found alongside those for Soualle in the Australian press at this time.²⁵ Indeed, to mark Soualle's departure from Goulburn in February 1855, a breakfast was thrown in his honor, at which Hauser was an invited guest, with the *Goulburn Herald* noting that the latter was "the other of the twin stars that have shone in our musical firmament."²⁶

Soualle's programs comprised a potpourri of light classical fare that was typical for such concerts at the time, and regularly included many of his own compositions. Perhaps because of his own familiarity with military music-making, local bands were often invited to join him. His program at the Mechanics' Institute in Melbourne on 5 August 1853 may be taken as representative, comprising overtures from Auber and Mozart played by the band, operatic arias from Bellini, Rossini, and Donizetti given by a variety of singers, and a range of pieces by Soualle himself, including a "Sultana Ugalda Polka," a "Fantasia," and two pieces "composed expressly for the concert": "Cheerily Men," described as a sailor's song, and a waltz titled "L'Australienne."²⁷ The latter provides the first evidence of Soualle's tendency to record his travels in the titles of pieces he composed en route, notably in those works described as "Souvenirs" (Soualle's compositions are considered in more detail below). He also engaged local artists to support or augment his concert programs. On 14 April 1855, for example, at a concert in Wellington, New Zealand, an

24. See *The Sydney Morning Herald* 21 December 1854, 1; 26 December 1854, 1; 28 December 1854, 1; and *Bell's Life in Sydney and Sporting Reviewer*, 30 December 1854, 2.

25. See for example "Matters Musical—The Hungarian [*sic*] and the Turk," *The Empire* (Sydney), 1 February 1855, 5.

26. Repeated in the *Bathurst Free Press and Mining Journal* 10 February 1855, 2. Hauser later published the various letters he had written during his travels as *Aus dem Wanderbuche eines österreichischen Virtuoso: Briefe aus Californien, Südamerika und Australien* (Leipzig, 1860). Perhaps unsurprisingly, given the rather different musical firmaments that they occupied, there is no mention of Soualle in this.

27. *The Argus* (Melbourne) 5 August 1853, 3.

audience of over three hundred people “heard his unfortunate lady accompanist struggling to keep up with him.”²⁸

Exactly when Soualle left the antipodes is unclear. The last press references to his activities are in June 1855, but his orientalist influence was certainly still being heard in June 1856, since the band of the Fortieth Regiment was performing his “Turkish Polka” in Melbourne that month.²⁹ Presumably Soualle had left the parts for the music in the country (a notable gesture given that they would have been handwritten), since he had by then long moved on elsewhere.

1856: Singapore, China, and Hong Kong

By November 1855 Soualle was in Singapore, and advertising a concert there on the 15th of that month.³⁰ The city provided a springboard for a number of concert trips around east and south-east Asia. One press report suggests he visited Batavia (now Jakarta),³¹ which would account for his “Souvenir de Java,” and it seems most likely that his “Souvenir de Manila” would have been inspired by a similar trip to the Philippines around this time, although no specific record has been uncovered. In 1856 Soualle travelled to Hong Kong, where he gave three concerts in August of that year, before sailing to Shanghai. Further evidence of the trailblazing nature of his activities is provided by the *North China Herald’s* description of his concert on 19 September as “the first public concert (properly so called) that has ever been given at Shanghai.”³² But expatriate publications of this kind were mixed in their assessment of Soualle’s act, and particularly the saxophone. The *Herald* observed that “the compass of the instrument is very great but we confess to some disappointment as regards its quality of tone, and correctness of tone also, in some few notes, and altogether we think it an imperfect instrument—it may however, improve on further acquaintance.” The writer suggested that the “turkophonini” (most likely a modified version of the soprano saxophone) was “by far the most perfect and pleasing instrument of the two,” whereas the *China Mail* rather patronizingly asserted that “the instrument is well adopted for that class of music” and felt unable to speak

28. John Mansfield Thomson, *The Oxford History of New Zealand Music* (Auckland: Oxford University Press, 1991), 23.

29. *The Argus* (Melbourne) Friday 13 June 1856, 8.

30. *The Straits Times*, 13 November 1855, 4.

31. *Ibid.*

32. Quoted in J. H. Haan, “Thalia and Terpsichore on the Yangtze: A Survey of Foreign Theatre and Drama in Shanghai, 1850–1865,” *Journal of the Hong Kong Branch of the Royal Asiatic Society* 29 (1989), 173.

of the instruments “in *very* warm terms of praise at least as regards their suitability for solo performances.”³³ As ever, in matters of musical taste, such sentiments were not uniformly held. The editor of the *Herald* felt obliged to offer the comment a few days later that “the critique of our reporter has been much discussed in fashionable circles and the correctness of his judgement as to the perfection of these new instruments questioned.”

Soualle then returned to Hong Kong, giving a further concert there on 16 October, before sailing back to Singapore and on to India. A review in the *Singaporean Straits Times* from 2 December gives a good overview of his act, noting that he played on

the Turkophone, Turkophonini, Grand Clarionet, Petit Clarionet, and an instrument which produced sounds in imitation of the Scottish Bagpipes, and elicited great applause. Mr Ali Ben Sou Alle also displayed his vocal powers by singing “Partant Pour La Syrie” and “Les Canotier[s] de Paris” accompanying himself on the Harmonium. Mr. Hewetson Junr. presided at the Piano Forte. The band of the 38th M.N.I was present and played several pieces of music, one of which, the “Battle of the Alma Polka”—composed by Mr. Ali Ben Sou Alle—was much praised.³⁴

1857–63: India, South Africa, Madagascar, Mauritius

By 1857 Soualle had moved on to the Indian subcontinent, with the French-language *Moniteur Official* of India reviewing two concerts given in Pondicherry that year. Reprinting these articles for its Parisian readers, the *RGMP* made it clear that there was in fact little difference between Soualle’s turkophone and Sax’s saxophone, and that it was an error of other newspapers in describing it as a new invention.³⁵ Soualle’s concerts comprised the by now familiar mix of light classics and original works, including his various souvenirs of Java, Ireland, and Shanghai, together with fantasias on a variety of themes, including one drawn from Mozart’s *Don Giovanni*. Several writers, seemingly following claims made by Soualle himself, have asserted that Soualle spent time working for the Maharajah of Mysore (now Mysuru), and that he also converted to Islam during this period.³⁶ There is no independent verifi-

33. All quotes taken from *ibid.*, 198–99.

34. *The Straits Times*, 2 December 1856, 4.

35. *RGMP*, 21 June 1857, 204–5.

36. Segell, *The Devil’s Horn*, 24. Rice, “Making and Improving the Nineteenth-Century Saxophone,” 91. Chouraki, “Ali-Ben-Sou-Alle: Un Mystérieux Saxophoniste du 19^e Siècle.”

cation for this, although Soualle almost certainly was in India, particularly since his *Souvenirs de L'Inde* is dedicated to "Governor Lord Harris," who was Governor of Madras in the late 1850s. But the religious conversion seems quite unlikely and is almost certainly a consequence of the story-telling with which Soualle embellished his act to enhance its mystique.³⁷

Later that year Soualle journeyed across the Indian Ocean to the island of Mauritius, arriving there in October 1857.³⁸ The *Port Louis Gazette's* announcement of his arrival is worth repeating at length, as an indication of the marketing material that Soualle was by now releasing in support of his act:

For these last three or four years Ali-Ben-Sou-Alle has been delighting and astonishing all parts of Australia and India with his extraordinary talent. His principal instrument is the turkophine [*sic*], which combines all the melody and sweetness of the flute with the roundness and depth of the French horn. It possesses a peculiar richness and fulness [*sic*] of tone, and is of great compass, while it is capable of the most rapid execution. Besides this instrument Ali-Ben-Sou-Alle plays on the turkophinini [*sic*], with which he imitates the scotch bagpipes, and sings the Scotch airs in such a way as to entrance the patriots of Scotland. The most popular of Moore's melodies he plays admirably,³⁹ as well as an endless variety of selections from the most familiar operas. With all these attractions, besides a picturesque and graceful costume, and a handsome and commanding appearance, Ali-Ben-Sou-Alle will be sure to attract a well-filled theatre.⁴⁰

Soualle appears to have particularly enjoyed Mauritius, and over the next six years he would spend several long sojourns there. But this first visit was comparatively short, and by February 1858 he was already in

37. If Soualle was indeed in the employ of the Maharajah, this would have been Krishnaraja Wadiyar III (1794–1868), who provided spiritual and cultural leadership when Mysore was under British administration. This Maharajah was a renowned and enlightened patron of music and other arts, and it is possible that he supported and encouraged Soualle in some way. But, notwithstanding that Islamic culture was prevalent in Mysore at the time, Krishnaraja Wadiyar was a Hindu, and it is therefore less likely that he had any particular interest in encouraging Soualle to convert to Islam, or that Soualle would have chosen to do so under these circumstances.

38. It is possible that Soualle's departure from India was a consequence of the 1857 Indian uprising against British rule. However Mysore, as a princely state, did not join the rebellion, and thus its direct impact on Soualle's activities is likely to have been minimal.

39. A reference to the Irish poet, bard and songwriter Thomas Moore (1779–1852), who published in 1806–07 a collection of Irish melodies to which he had contributed lyrics, and which enjoyed notable popular success at the time.

40. Originally published in the *Port Louis Gazette*, 9 October 1857. Reprinted in *The Sydney Morning Herald*, 30 November 1857, 5.

South Africa, probably having arrived in Cape Town on the 22nd of that month. His first concert was given a few days later, on 4 March.⁴¹ Following the pattern he had established in Australia, over the next twelve months Soualle gave numerous concerts among European expatriate communities in South Africa, in towns as diverse as Fort Peddie, King William's Town, Alice, Fort Beaufort, Bedford, Somerset, and Cradock,⁴² and by December 1858 he had arrived in the larger town of Durban. His stay there was reflected on some fifty years later by one George Russell, who had immigrated there in 1850. Russell repeats a contemporary newspaper's observation that "the whole of this performance, both instrumental and vocal, elicited the warmest applause. Ali Ben Sou Alle's gorgeous and costly dress and commanding graceful presence added to the effect."⁴³

Other local papers hint mischievously at Soualle being nursed through a period of illness by the wife of his Durban host, a British expatriate named William Fraser, who then transferred her affections to the French musician, only to have her own heart broken when Soualle left Durban in March 1859.⁴⁴ A different concert, given further inland at Graaf Reinet, was notable for Soualle's performances being interspersed with what appears to be a blackface minstrelsy act, in which "a young gentleman amateur set the audience in a roar of laughter by singing some negro melodies, accompanying himself on the banjo."⁴⁵ There are no other references to Soualle's performances being similarly twinned with such minstrelsy, but the obvious overlap between the exotic "Turk" and "Negro" in the mid-nineteenth century European popular imagination may have made this sharing of the concert stage appear very appropriate to this particular audience.

Soualle left South Africa on 30 March 1859,⁴⁶ and by April he was once again in Mauritius, giving a benefit concert in support of the nearby island of Réunion, where a cholera epidemic had recently bro-

41. Steltzner, "The History of the Clarinet in South Africa," 151.

42. *Ibid.*, 152.

43. George Russell, *The History of Old Durban and Reminiscences of an Emigrant of 1850. Illustrated* (London: Marshall & Co., 1899), 386. Originally published in *The Natal Mercury*, 20 December 1858, Supplement, 1.

44. See Shelagh O'Byrne Spencer, *British Settlers in Natal 1824–1857: A Biographical Register* (Pietermaritzburg: University of Natal Press, 1981), 207.

45. This from the *Cape Monitor* (date unknown), reprinted in *The Derbyshire Times and Chesterfield Herald*, 24 December 1858, 4.

46. Steltzner, "The History of the Clarinet in South Africa," 154.

ken out. The local *Mauricien* newspaper observed that not only did Soualle's generosity equal his talent, but that the 1104 piastres the concert raised was "an enormous figure for our little theatre and which we should attribute, in large part, to the public sympathy for our neighbours."⁴⁷ This may have been the same benefit concert that stimulated a rather flowery and poetic review from "Matou," (possibly the pseudonym of Petit d'Hauterive), who noted that Soualle's generosity in giving this concert should change the old proverb to say "as generous as a Turk."⁴⁸ Soualle's willingness to give such benefit concerts appears to have made him popular. When he left again on 4 March 1860, the *Mauricien* noted that he had given eleven concerts on the island, "five of which alone were for his individual advantage," and that he had been sufficiently well received that "his last concert was as well attended as his first."⁴⁹

It is not clear where Soualle travelled after his departure from Mauritius. It seems likely that he returned to Paris, since he submitted a patent for his modifications to Sax's saxophone in September 1860 and a further addition to that patent in September 1861. Soualle's two patents (of which more below) are written in very different hands, and signed on his behalf by the two different lawyers depositing them. Therefore, it is not impossible that he was organizing the applications from elsewhere. But many of his compositions, published in Paris by L. Parent, bear the publication date of 1861, further suggesting that Soualle returned to the French capital around this time with manuscripts composed on his travels, and persuaded a publisher to engrave them. Curiously, if he was in Paris, there appear to be no references to any concerts he might have given at that time, but neither have any performances elsewhere currently come to light.

By July 1862 Soualle was certainly back in Mauritius, composing a piece titled "La Radamienne," also described as a "hymn national malgache," and performing it in honor of the coronation of Madagascar's Radama II in a concert in Port Louis on 5 July.⁵⁰ Soualle's extended

47. *Le Mauricien*, 9 May 1859 (page unknown). Reproduced at <http://www.potomitan.info/galerie/roussin/> (retrieved 24 November 2015).

48. Matou, *Guêpes Mauriciennes, Par Matou* (Paris: H. Plon, 1861), 83. Matou also confirms in his review that Soualle had originally travelled to Australia to seek his fortune prospecting for gold.

49. Originally published in the *Mauricien* newspaper on 7 March 1860. Reprinted in the *Sydney Morning Herald*, 17 March 1860, 5.

50. Claude Wanquet and Benoît Jullien, *Revolution Française Et Océan Indien: Prémices, Paroxysmes, Héritages Et Déviations* (Paris: Éditions l'Harmattan, 1990), 451. fn 31.

sojourns in Mauritius are unlikely to be explained by his musical activities alone. The mid-nineteenth century expatriate community there was quite small, and the novelty attaching to Soualle's act would quickly have worn thin.⁵¹ It seems likely that his entrepreneurial spirit was now manifesting itself in other ways and that he had business interests in the area, since on 24 October 1862 he submitted in Mauritius a patent for "Paste for the Manufacture of Paper," which was granted a few days later.⁵²

It is notable that his baptismal name had by now been left behind, even in these official patents, and that he was consistently identifying himself by his stage name. Nevertheless, generating a certain ambiguity around his true identity appears to have been part of his act. At one point in his travels around Australia he may have anglicized "Ben Sou Alle" to "Ben Sullivan," as part of a concert where several performers punningly changed their names.⁵³ In South Africa he appears to have taken the Sullivan persona one stage further, incongruously adopting the Irish moniker "Patrick Sullivan," as part of a concert given with the Forty-fifth British Infantry regiment in Durban in 1858.⁵⁴ Yet when he requested naturalization as a British citizen in Mauritius in 1863 he was listed as "Augustin Edouard Sou-alle, *alias* Ali-Ben-Sou-Alle."⁵⁵ Soualle's continual obfuscation of his personal identity may well have been part of an aspiration to blur the boundaries between life and art.

51. The white population of Mauritius in 1810 (the year in which slavery was abolished on the island) is estimated to have been 29,612, representing approximately one third of the total population. The population expanded notably from the 1840s onwards, but this was driven by significant numbers of migrant workers arriving from India; by 1861 their numbers had reached 192,634, and accounted for 62 percent of the overall population. Migrant workers from African and China were also present in large numbers. Thus, an increase in the numbers of white Europeans on the island from the 1810 figure would have been dwarfed by migrant workers, who were providing manual labor in the sugar plantations that white Europeans controlled. See Robert Chaudenson and Salikoko S. Mufwene, *Creolization of Language and Culture* (London: Routledge, 2001), 131, and Richard Blair Allen, *Slaves, Freedmen, and Indentured Laborers in Colonial Mauritius* (Cambridge: Cambridge University Press, 1999), 17.

52. "The Mauritius Almanac and Colonial Register for the Year," ed. The Colonial Office (Mauritius 1870), 271. The fact that this patent was submitted in Mauritius lends further credence to the idea that Soualle was back in Paris in 1860/61. He could conceivably have submitted the saxophone patents in Mauritius, had he been there.

53. Errol J. Lea-Scarlett, "Music Making in Early Sydney," *Miscellanea Musicologica: Adelaide Studies in Musicology* 5 (1970), 27.

54. Elaine Denby, *Grand Hotels: Reality & Illusion: An Architectural and Social History* (London: Reaktion Books, 1998), 304.

55. "A Collection of the Laws of Mauritius and Its Dependencies," (Mauritius 1868), IX.

1864–65: Paris and London

By 1864 Soualle had returned to concert stages in Paris and London. On 23 April he took part in a benefit concert given in aid of farmworkers' orphans, at the Grand Hotel in the Louvre, Paris, performing alongside a select cast of musical luminaries including the composer/violinist Wieniawski (who performed his own "Souvenir de Lubin" on the piano). Soualle's appearance provoked two laudatory articles: one by Marie Escudier in *La France Musicale*, and another in *La Semaine des Familles*.⁵⁶ Both served to re-introduce Ali Ben Sou Alle to Parisian audiences, recycling the now familiar stories pertaining to Soualle's travels, including his time with the Maharajah in Mysore, with the latter article also asserting that, notwithstanding these travels, "within this foreign name was retained a French heart."⁵⁷

Perhaps more important to Soualle than his francophone heart, however, was the wallet that nestled close to it, and shortly thereafter he travelled to London again for the summer season. Although Louis-Antoine Jullien had died in 1860, his son (also christened Louis) continued to mount summer promenade concerts in a similar vein to those of his father. But Soualle chose instead to join Alfred Mellon's competing concert season at the Royal Opera House in Covent Garden, performing there from August to October. A poster for one of these concerts, given on 18 August 1864, advertises him playing a set of variations on "In My Cottage" on the turkophone.⁵⁸ Mellon had brought together some of the top performers of the day: the pianist Marie Krebs, flutist Robert Pratten, and clarinetist Henry Lazarus, as well as the bassoonist John Winterbottom, who had now returned from his own antipodean adventures. That Soualle should not only be asked to join them but also billed more prominently than many of them demonstrates the reputation he had by then acquired, notwithstanding that he was usually placed last in the programs, his quasi-theatrical act obviously deemed to provide some light relief to the potpourri of light classical extracts that otherwise characterized the performances.

If Soualle had largely impressed the critics on his global travels, the London critics proved somewhat harder to persuade. They often

56. "Ali-Ben-Sou-Alle," *La France musicale* 28, no. 18, 1 May 1864, 135. "Chroniques," *La Semaine des familles* 32, 7 May 1864, 511–12.

57. *La Semaine des familles*, 7 May 1864, 512.

58. Concert program, Royal Italian Opera House, Covent Garden [London], 18 August 1864. Part of the McCann Collection at the Royal Academy of Music, London. Reproduced at <http://www.ram.ac.uk/museum/item/15800> (accessed 6 July 2016).

disparaged the musical content and aspirations of Mellon's concerts and were mixed in their views of Soualle's abilities. A review in the *Musical Times* sniffed that a "vapid fantasia" was played on "a new instrument [by] a gentleman with the unmistakably Oriental name of Ali ben Sou-Alle." Earlier the reviewer had noted of such concerts that "in the attempt to offer sufficient attraction to the educated and uneducated in art, a middle course is pursued which has the effect of disappointing both."⁵⁹ Although *The Daily News* noted that Soualle displayed a perfect command over his instrument,⁶⁰ *The Standard* observed that whereas nothing needed to be said of the fiddlers on the program, "less may be said of Ali-Ben Sou-Alle, the player on the turkophone, whose name might have been omitted from the program with credit and advantage."⁶¹ But if the critics disdained Soualle's performances, they were sufficiently popular with the general public that for his own promenade concerts Jullien *fils* dressed a clarinet player by the name of Tyler in a Turkish costume, by way of a spoiling act, who performed a series of saxophone solos under the improbable pseudonym of "Ali Ben Jenkins."⁶² In fact, one newspaper went so far as to describe him as "Ali Ben Jen Kins," deliberately mimicking the orthography of Soualle's alter ego. According to the same paper, Jenkins had "the house in roars when from a grave oriental march he breaks into "Sally in our Alley."⁶³ Soualle also made sufficient impression that a humorous poem about his performances appeared in the satirical magazine *Punch*, in which the curiosity value of the turkophone becomes a running gag, as exemplified by the lines: "Oh, what is a Turkophone?/ I cannot make out, I own/ Is it wind, is it string, oh what sort of thing/ Is this wonderful Turkophone?"⁶⁴

59. *The Musical Times*, 1 September 1864, 350.

60. *The Daily News*, 9 August 1864, 2.

61. *The Standard*, 10 October 1864, 3.

62. Jules Rivière, *My Musical Life and Recollections* (London: Sampson Low, Martons and Co, 1893), 126–7. Rivière's reflections were published long after the event. He appears to have misremembered Soualle's name as "Cordier," and describes his stage persona as "Ali Ben Mustapha." There are no other contemporary references to either of these names. His recollections regarding Tyler may be more accurate. The Tyler family (father George and his sons Joseph and George junior) were multi-instrumentalists who appeared regularly on London's concert scene in the mid-nineteenth century. The family is listed as playing saxophones at a concert at St. Phillips Church, Kennington, on 18 March 1869 (*The Musical World*, 3 April 1869, 237).

63. *Dundee Courier and Argus*, Wednesday 5 October 1864, 3.

64. *Punch*, 3 September 1864, 100.



FIGURE 2. Soualle photographed in London in 1864. UK National Archives.⁶⁵

Whatever the newspaper critics felt of Soualle's act, he appears to have had sufficient celebrity status that at some point in 1864 he was invited to perform in front of the Prince of Wales, to whom he gave a bound copy

65. This image was supplied by the UK National Archives. The catalog indicates that the picture was registered by its photographer (Adolphe Naudin) on 4 October 1864, suggesting that it was taken around that time. In addition to its historic interest in relation to Soualle, it is also probably the earliest photograph (as opposed to sketch) of a saxophone.

of many of his published works.⁶⁶ Different pieces in this collection indicate saxophone or turkophone as the melody instrument, and there are also some songs and pieces for solo piano, demonstrating Soualle's wider musical gifts.⁶⁷ Later that year, in December 1864, Soualle gave his first performance in his home town of Arras, northern France.⁶⁸ Given his international exploits and his minor celebrity status at the time, this must have felt something like the return of the prodigal son for one of the most successful graduates of Arras's small music conservatoire. Soualle's reputation was by now sufficiently high that he was invited to join singers from the Théâtre Italien in Paris for concerts at the Tuileries palace and l'Hôtel de ville (City Hall) on 27 March and 1 April 1865. The *RGMP* records that Soualle had been called to perform before "their majesties" (presumably Emperor Napoleon III and his wife Empress Eugénie) at the Tuileries, as part of a series of concerts that were by then an annual feature during the Lenten period at the French court.⁶⁹

1866–99: The final decades

After these successes, Soualle's celebrity status appears to have waned, and reports of his appearances are increasingly sporadic. He seems to have given concerts in the south of France through 1866, and his presence in that region would appear to be confirmed by the last of his published compositions, the 1866 "Toulouse-polka" for piano solo. The short-lived journal *Jean qui rit*, published in the southern French town of Pau, provided a review of two concerts given by him in January 1866 and there was at least one further concert given in Perpignan on 2 July.⁷⁰ Attention was drawn by *La Comédie* in July to the opening of a

66. This work appears to have been collated in Paris by L. Parent in 1864, under the title "Royal Album for Saxophones."

67. This meeting must have been prior to 1 August 1864, since *The Morning Post* noted on that day that Mellon had engaged "the celebrated Oriental Instrumentalist Ali Ben Sou Alle who . . . has had the honour to perform before H.R.H the Prince of Wales, who expressed the highest appreciation of his talent" (*The Morning Post*, 1 August 1864, 1). In repeating the story in 1865 the *RGMP* (2 April 1865, 110) asserted that Soualle had performed in front of "the Queen and Prince of Wales." But this appears improbable, given Queen Victoria's self-imposed isolation at this time. It is notable that the first piece in the "Royal Album" is dedicated to "Her Royal Highness the Princess of Wales," and is eponymously titled "Alexandra—Royale Polka," suggesting that she was present at the performance rather than the Queen.

68. *The Musical World*, 31 December 1864, 844.

69. *RGMP*, 2 April 1865, 109–10.

70. *Jean qui rit*, Pau, 25 January 1866, 3–4. *Le journal de Pyrénées Orientales*, 22 and 29 June 1866 (the latter retrieved from <http://www.institutdugrenat.com/2015/10/passage-du-musicien-ali-ben-sou-alle-a-perpignan-en-1866/>, accessed 17 June 2016).

new variety theatre in Beziers, at which Soualle was rumored to be appearing, but there is no evidence of the concert actually taking place.⁷¹

But these 1866 references provide the last record, at present, of Soualle's performances, and from this point on his activities, and references to them, become yet more enigmatic. A short story titled "La Fortune et la Clarinette" written by "B. Saint Marc" (the pen name of the writer Agricola Beynet) published in *Le Monde Illustré* in November 1872 provides a highly romanticized version of Soualle's time in India, and a description of the meeting with the maharajah in Mysore, at which the writer claims to have been present. However, it appears to be a revised version of an elaborate story first published around 1860,⁷² suggesting that Beynet became aware of Soualle's activities on the latter's return to France at that time. In the earlier version Soualle's name is mistakenly (or perhaps deliberately?) written as "Loualle" and the character plays a smaller role in a complex overall narrative based around conversations at the Palais Royale. In the revised 1872 version the description of the first meeting with Soualle—"after a night of walking through forests of gigantic trees, oaks, sapirs, cypresses, poplars, palm trees, banyan trees (fig pagodas), without having been devoured by tigers or impaled by rhinoceroses"⁷³—illustrates the flowery rhetoric of the narrative, and the story is further adorned by an account of a fiancée Soualle supposedly left behind, but who had married another man, as he discovered when he returned to France to place his Indian riches at her feet. The story is highly fanciful and appears to contain little more than occasional kernels of reality, but Beynet was obviously knowledgeable of Soualle's activities, and the revised version of the story was deemed worthy of being republished in *La Mosaïque* in 1880.⁷⁴

Soualle's story takes a final enigmatic turn in the pages of *Le Figaro* between 1875 and 1877. A cryptic notice in May 1875 advertises the coming arrival of "Docteur Soualle" in the autumn,⁷⁵ and this is followed in December by a short article titled "Une future célébrité Parisienne." The latter was almost certainly planted by Soualle, since it now serves to advertise his transformation from globally itinerant musician to quack

71. *La Comédie*, 1 July 1866, 6.

72. B. Saint-Marc and Le Marquis De Bourbonne, *Les Chroniques Du Palais-Royale* (Paris: L. Baillière et H. Messenger, ca.1860), 295–340.

73. *Ibid.*, 297.

74. *Le Monde Illustré*, 9 November 1872, 287–90; *La Mosaïque: Revue pittoresque illustré* 8 (1880), 142–3.

75. *Le Figaro*, 30 May 1875, 3.

doctor. Retelling the familiar story of his international travels, his time in Mysore is now inflected to cast himself as one of the early victims of the 1857 uprising. Afflicted by rheumatism which “seized all his body” on his return to Europe, he remembered the restorative power of certain Indian herbs and “sailed to fetch them and heal himself completely.” Needless to say, Soualle was willing to pass on his expertise in the medicinal properties of Indian herbs to those suffering from gout, rheumatism, neuralgia, etc., to anybody willing to visit him at his new establishment at 350 rue Saint-Honoré in Paris.⁷⁶ A follow-up article in October 1876 (“Une prophétie réâlîsêe”) endeavored to promote Soualle’s perceived successes over the past year, as well as introducing his “merveilleuse” “Essence Soualle.”⁷⁷ A final advertisement for Soualle’s business appeared in January 1877, and the lack of any further announcements thereafter suggests that Soualle’s Essence was perhaps not quite as marvelous as was claimed.⁷⁸

These *Figaro* references provide at present the final sightings in the historical record of Soualle’s unceasing entrepreneurialism. He died in Paris on 21 September 1899, aged 75, although it is not clear how he occupied himself in his final decades.⁷⁹ It might be assumed that, like Adolphe Sax, whose most well-known innovation Soualle developed and exploited, he passed his final years in some degree of penury, with neither music nor temporary celebrity status in the 1860s having yielded sufficient financial reward to provide for a comfortable dotage. But there is no evidence to support either this supposition or any contrary one.

The word “turcophone,” in its French orthography, does resurface occasionally after 1866: a popular song with that title was being heard in Oxfordshire in the late 1870s, and there was even a horse, owned by the Duke of Portland, who was given that name in 1886 and raced with some success in the late 1880s. It is difficult to know whether either of these was influenced by Soualle’s activities—although the former seems more likely than the latter—but if so, we may infer that in some small

76. “Une future célébrité Parisienne,” *Le Figaro*, 12 December 1875, 2. The same piece was reproduced in *La Vie Parisienne*, 18 December 1875, 714.

77. “Une prophétie réâlîsêe,” *Le Figaro*, 26 October 1876, 2.

78. *Le Figaro*, 17 January 1877, 8.

79. The registration of Soualle’s death can be viewed in the online archive of the Mairie de Paris. The reference is DIM9 928, which records deaths registered in the 11th arrondissement between 1893 and 1902. The entry is on the verso of p. 95. See http://canadp-archivesenligne.paris.fr/archives_etat_civil/1860_1902_tables_decennales (accessed 18 July 2016).

way Soualle, his alter ego, and his renamed saxophone remained in European cultural memory for some time after his own musical activities had ceased.

Soualle and the saxophone

Although Soualle (and Jullien) sought to employ neologisms such as “corno-musa” and “turkophone”—probably to avoid the risk of litigation over an instrument still covered by Sax’s patent—there is no doubt that he performed on a saxophone. Yet his instruments were modified from Sax’s original designs in some important ways. As can be seen in fig. 2, he played on straight instruments with a slightly turned bell, but without the distinctive “U” bend that characterizes most saxophones then and now. Not immediately evident from the photograph, however, are several modifications Soualle made to the key work, which he set out in a patent submitted in 1860 (supplemented by a patent addition in 1861).⁸⁰ Inspired by Auguste Buffet’s Boehm-system clarinet key work, these included revisions to the fingering system for the lower notes of the instrument and, more intriguingly, a revision to the octave-key mechanism.⁸¹

The first of these comprised additional keys and linkages that more easily facilitated certain patterns involving the little fingers of each hand (fig. 3).⁸² They would certainly have made the instrument feel more comfortable for a clarinetist used to the cross-finger relationship on Buffet’s clarinet, in which certain notes could be produced by either the right-hand or left-hand little finger (e.g., f-sharp/c”-sharp).⁸³ But perhaps more significant, and impactful, were Soualle’s modifications to the saxophone’s octave mechanism, as a brief explanation of that mechanism’s evolution will illustrate.

The saxophone has a conical bore and overblows at the octave, like the oboe, rather than at the twelfth, like the clarinet. The player thus uses many of the same fingerings to get the same notes in the upper and lower registers, with the thumb operating a single key that opens one or

80. French patent no. 46837, 22 September 1860: “Perfectionnements apportés aux instruments de musique à clefs” (certificate of addition, 21 September 1861).

81. Since none of Soualle’s instruments appear to have survived, we cannot be sure who actually built them for him. Al Rice has suggested (personal correspondence) that Buffet himself is the most likely candidate.

82. See also Rice “Making and Improving the Nineteenth-Century Saxophone,” 92–3.

83. See Eric Hoeprich, *The Clarinet* (New Haven and London: Yale University Press, 2008), 173.

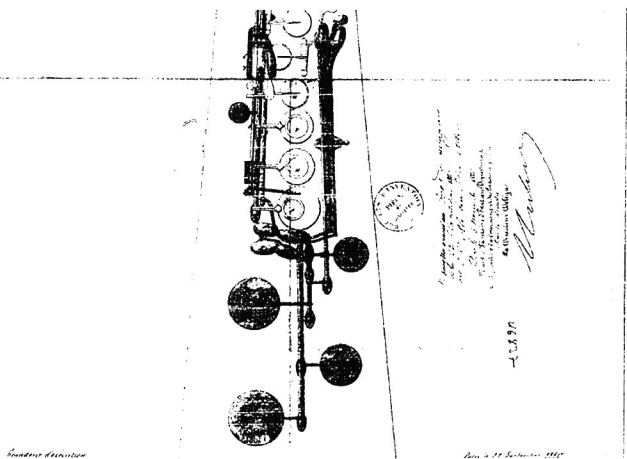

FIGURE 3. Detail from Soualle's 1860 patent, showing Boehm-style key work applied to the lower keys of the saxophone.

the other of two small vents located towards the top of the instrument. Today, this octave key enables an automatic mechanism that governs which vent is called into operation, depending on the disposition of the players' fingers. Modern manufacturers are generally consistent in their approach to these two vents, the first of which produces the notes *d*" to *g*"-sharp, and the second all notes above this, usually *a*" to *f*"-sharp.

Sax's original design used two octave keys to obtain these higher notes. In fact, Sax's first intention was to provide three octave keys for the instrument, as is evident from his 1846 patent. This contains sketches for the proposed family of saxophones, although only two contain any detail. An upward pointing instrument, described by Sax as a "bourdon," evidences the relationship with the ophicleide on which the original saxophone design was based; the three octave keys proposed by Sax for this bass instrument are numbered as 18, 19, and 20 in the patent sketch, and confirmed in the accompanying text (fig. 4). The more familiar S-shaped saxophone, described in the patent as a "tenor-baritone," equally clearly has only two octave keys, numbered as 16 and 20 (fig. 5). As might be expected from the still-evolving saxophone family, there was much inconsistency in the mid-nineteenth century about the most

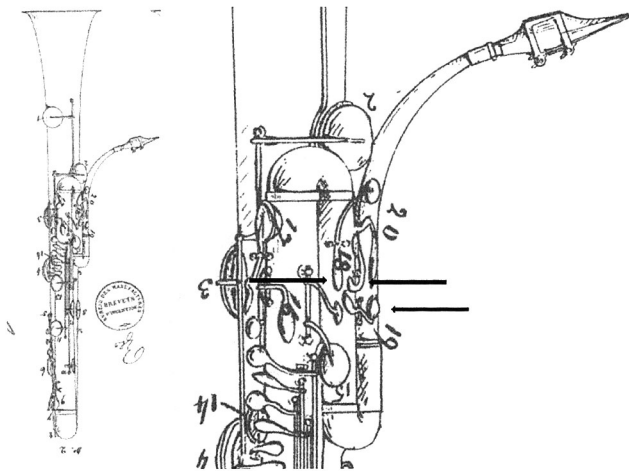

FIGURE 4. Detail of 'bourdon' saxophone from Adolphe Sax's 1846 patent, showing three octave keys.

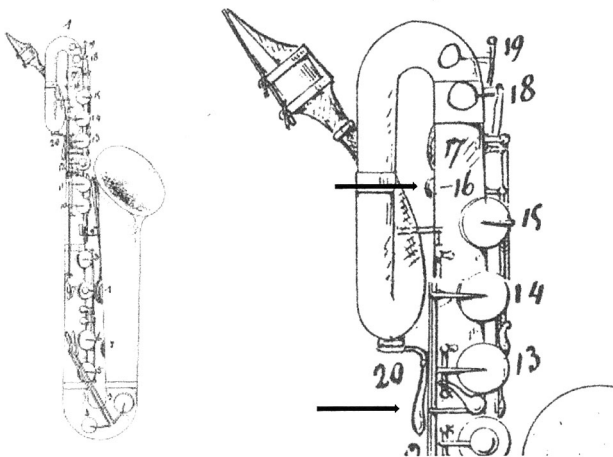

FIGURE 5. Detail of 'tenor-baritone' saxophone from Adolphe Sax 1846 patent, showing two octave keys.

desirable point at which to shift between these two octave keys, with different methods or patents suggesting different changeover points.⁸⁴ But the provision of two octave keys on all saxophones was the norm until 1888, when Arsène Lecomte patented what is usually taken to be the first automatic octave mechanism for the instrument.⁸⁵ Lecomte combined the two previously independent octave keys into a single key that operated two vents according to context: the correct vent for the note required would open automatically, rather than having to be opened manually by the player's left thumb choosing between two separate keys, as on Sax's system.⁸⁶

The title of Lecomte's patent—"L'application du système Boehm aux saxophones"—makes clear the inspiration for his innovations. And like Soualle, he proposed not only changes to the octave key mechanism but also modifications to the keys producing the lowest notes, recalling the left-hand/right-hand fingering of the Buffet-Boehm clarinet. Yet, despite the historical significance normally ascribed to Lecomte's innovation, he was not the first to devise an automatic octave mechanism for the saxophone. That accolade properly belongs to Soualle, who notes the problem with Sax's design in the text of the patent he submitted in 1860:

We know that two keys called chalumeaux are necessary to traverse the higher octave, in which the change of keys is effected with the thumb of the left hand, on some saxophones between *g* and *a*, on others between *a* and *b*. This passage between one key and the other was painful and very defective; the problem was therefore to find a way to do without it. I have achieved this

84. Kastner's 1846 method, written in conjunction with Sax, asserts that the appropriate point for changing between these two octave keys is *g*"-sharp. That is, the lower octave key should be used for *d*" to *g*", and the higher key should be used for notes for *g*"-sharp and above. Methods by Cokken and Hartmann published the same year replicate this information. But a new edition of Kastner's method published by Brandus in 1850 includes a revised fingering chart. The change between octave keys is now indicated as occurring at *a*"-sharp, not *g*"-sharp, perhaps suggesting that the holes covered by these keys had been repositioned. And Sax's Belgian patent of that year indicates that the tenor saxophone, uniquely, should have a changeover point at *c*", again demonstrating the developmental nature of the family as a whole.

85. It might be noted in passing that in 1866 Millereau and company submitted a patent for an instrument to be called a "Saxophone-Millereau." Unsurprisingly, Millereau's instrument was similar to Sax's design, except that the two octave keys were now mounted on a single post rather than each having its own fixing, although the two keys remained independent. See French Patent no. 72930, 7 August 1866, Fr. Millereau: "Un système de musique à vent et en cuivre dit saxophone-Millereau."

86. French patent no. 193722, 1888: "L'application du système Boehm aux saxophones."

in a fully satisfactory manner, by the application of a new key and a particular mechanism that are the subject of the second part of my invention.⁸⁷

Later in the patent text Soualle makes clear that the changeover point of this mechanism occurs at *a*''; that is, the last note for which the lower of the two octave vents functions is *g*''-sharp, as with today's instruments (fig. 6). This was a semitone above the changeover point advocated by Sax in 1846.

Fig. 6 illustrates the detail of Soualle's system. It shows a bifurcation above the octave key (1), which keeps the lower octave vent closed when required; an additional thumb plate on the left (2), undoubtedly borrowed from Buffet-Boehm; and a link to the G key (3), which determines whether the lower or upper octave vent will be called into operation. While this may appear a relatively minor technical innovation, it can be argued that it enabled Soualle to be more virtuosic than other players at the time. Indeed, Soualle was one of the first virtuosos on the saxophone. He made a career from presenting concerts comprising what we might now see as emergent forms of popular music, to audiences who expected undemanding musical novelty. In particular, they wanted to hear virtuosity, and Soualle's surviving scores demonstrate that this is what he supplied. His relatively slight compositional output consists of short miniatures designed to show off his prowess on the instrument.⁸⁸ The musical language comprises conventional harmonic and melodic formulas, incorporated within short forms such as fantasias and caprices. The theme-and-variation form, commonly used in such instrumental display vehicles during this period, is especially favored, and erstwhile dance forms such as allemandes, waltzes, polkas, and polonaises

87. Page 3 of the patent text notes: "On sait que deux trous dits chalumeaux sont nécessaires pour parcourir l'octave supérieure dans laquelle le changement des clefs s'opère avec le pouce de la main gauche, sur certains saxophones entre sol et la, sur d'autres entre la et si. Ce passage d'une clef à l'autre était pénible et très défectueux, le problème consistait donc à trouver le moyen de le supprimer. J'y suis parvenu d'une manière complètement satisfaisante, par l'application d'une clef nouvelle et du mécanisme particulier qui font l'objet de la seconde partie de mon invention."

88. Copies of much of Soualle's music are held both at the Bibliothèque nationale de France (where they are usefully summarized at <http://data.bnf.fr/documents-by-rdt/13994856/220/page1#header>) and at the British Library, which retains the bound volume of his various sheet music publications that was given to the Prince of Wales in 1864 (*Royal Album pour Saxophones par Ali-Ben-Sou-Alle*; Music Collections R.M.26.d.7). The details of the latter collection are listed in Mollica, 168–70. It is perhaps an indication of the ongoing fascination with Soualle that many of his compositions have recently been offered in modern editions by Musik Fabrik Music Publishing.

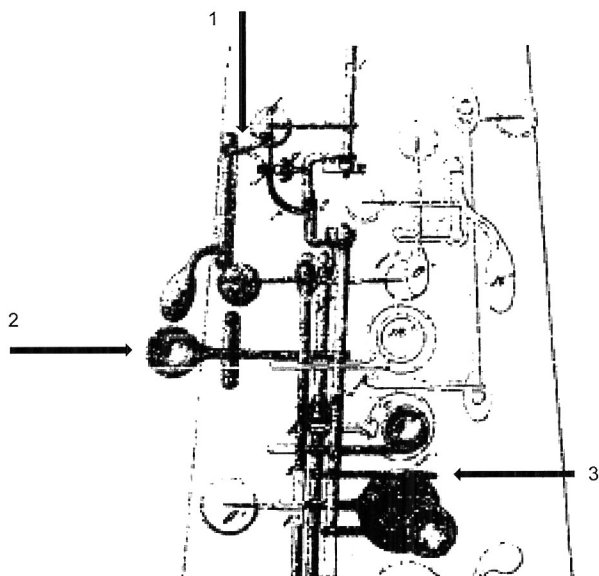

FIGURE 6. Detail from Soualle's 1860 patent, showing his automatic octave mechanism.

are widely employed. The extract from Soualle's "Grand Fantaisie Variée sur Lucie de Lamermoor," shown in fig. 7, may be taken as representative.

While this kind of writing is common for flutists and clarinetists in the 1850s and '60s, it is much less common in those few saxophone works or studies that were written for the—admittedly still rare—saxophone soloist.⁸⁹ And although the benefits accruing from Soualle's addition of the left-hand/right-hand linkages to the instrument's lower notes are not immediately evident in his scores, those arising from his revised octave mechanism certainly are. Fig. 8 shows an extract from fig. 7 marked up with the thumb changes necessary on saxophones

89. Most saxophone soloists at this time were military musicians who would have graduated from the *Gymnase Musical Militaire* and performed in the rather more utilitarian contexts of regimental bands.

FIGURE 7. Extract from Soualle's "Grand Fantaisie Variée sur Lucie de Lamermoor," showing his virtuosic saxophone writing.

with two octave keys, which would have required 29 thumb movements. Fig. 9 shows the reduced number of changes needed (23) under Soualle's system, and illustrates that the slightly cumbersome thumb movements from one octave key to another—the adjacent 1s and 2s in Fig. 8—that he had complained about in his patent text, have been

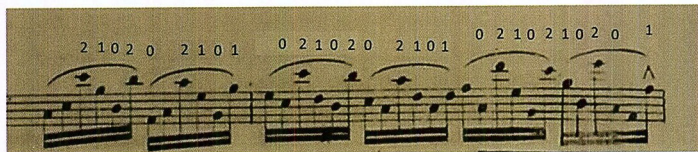

FIGURE 8. Extract from Soualle's "Grand Fantaisie Variée sur Lucie de Lamermoor" (p.7), showing thumb changes required using two octave keys (29 movements).

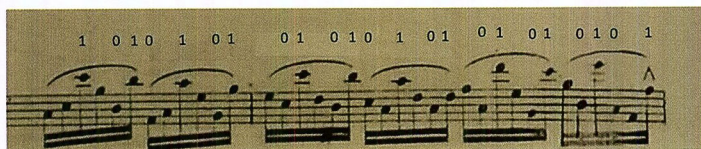

FIGURE 9. Extract from Soualle's "Grand Fantaisie Variée sur Lucie de Lamermoor" (p.7), showing thumb changes required using Soualle's modified octave mechanism (23 movements).

obviated. Soualle's automatic octave mechanism offered an obvious advantage, which is why, once Lecomte had devised something similar and began offering his version, it became widely adopted in the late-nineteenth and early-twentieth centuries, and the two-key system eventually disappeared entirely.⁹⁰

Conclusions

Soualle's story combines the exoticizing curiosity of the mid-

90. Even after Lecomte's introduction of the automatic octave mechanism in 1888, it would take quite some time before this became standard. The C. G. Conn company, for example, did not adopt this mechanism until 1906. Ben Vereecken's saxophone method, published in 1917, nearly 30 years after Lecomte's patent, contains separate exercises for the first and second octave keys, demonstrating that at that date there were still many players performing on instruments that made such skills necessary. The Buescher company did not offer an automatic mechanism as standard until 1921. See Paul Allen Bro, "The Development of the American-Made Saxophone: A Study of Saxophones Made by Buescher, Conn, Holton, Martin, and H.N. White" (DM diss., Northwestern University, 1992), 76.

nineteenth century global explorer with the pragmatism of the entrepreneurial working musician. He was a musical pioneer who achieved a small degree of eminence in two of the most significant musical centers of western Europe in the mid-nineteenth century: London and Paris. He traveled throughout the British and French empires, functioning as both musical emissary and showman, thus allowing expatriate communities the opportunity to remain connected to musical developments happening “back home.” He enhanced his *Ali Ben Sou Alle* alter ego by performing on a slightly modified version of the saxophone, an instrument largely unknown, and almost certainly previously unheard, by those who formed his audiences in the 1850s and early ‘60s. It is ironic that while Adolphe Sax was struggling at the time to establish the instrument in Europe’s major musical metropolises, its sound, if not Sax’s name, was becoming more familiar in many expatriate communities around the world, because of Soualle’s prodigious touring. Soualle did not make the instrument a success; that came about because of its increasing use by military bands around the world from the late 1870s onwards, followed by its adoption into American popular music around the turn of the 20th century. But he did keep the saxophone flame alive at this time. Had he been a less peripheral figure in the Parisian musical world, and spent more time in the city, he might have been more influential.

Notwithstanding the similarities between their patents, there is no evidence that Arsène Lecomte was aware of Soualle’s previous efforts when he patented his own automatic octave mechanism in 1888. But why, given the obvious musical advantages, were Soualle’s innovations not capitalized upon? There are several possible explanations. First, the saxophone was under patent. Until 1866 Sax controlled what might and might not be done with it, and he was quick to resort to litigation to protect his rights. Sax’s 1846 patent was initially granted for 15 years. Soualle would have been under the impression that it expired in 1861, and it seems unlikely to be a coincidence that his own patents were submitted around this time; he spent much of the 1850s touring, but he may well have returned to Paris largely for this reason. However, very unusually, Sax was granted a five-year extension to his original patent, perhaps thwarting Soualle’s plans. But Soualle returned to Paris and London again between 1864 and 1866, this time giving concerts in both these cities and elsewhere. Might he have returned for the same reason, knowing that Sax’s patents would finally expire? We cannot be sure. There is certainly no evidence that he persuaded a manufacturer to adopt his

ideas. But perhaps, by the time of his later return in 1864, Soualle felt that the saxophone was not particularly successful, and there was thus little opportunity of a commercial return on the innovations he proposed. Although the saxophone was adopted by some francophone bands in the 1850s and '60s, it was not more internationally widespread until the 1870s and '80s. Lecomte's innovations were not only more timely, but as an established manufacturer he also had the capacity to adopt them more easily.⁹¹ And, as fig. 2 illustrates, Soualle played on straight, not curved instruments. While this would have made little difference to the implementation of his octave mechanism, adapting curved saxophones to accommodate his modifications for the lower keys would have been more technologically challenging and expensive. This alone might have put off any instrument makers he approached with his ideas. Furthermore, by the mid-1860s Soualle's orientalist performances were clearly seen as populist and perhaps gimmicky, and, unlike both Sax and Lecomte, he was not part of the Parisian instrument manufacturing scene. He was a performer and a traveler, an opportunist and a showman, with few networks and little social capital to call on when trying to get his innovations more widely accepted, notwithstanding their obvious musical benefits.

But perhaps Soualle's most significant legacy is that his performances associated the saxophone with forms of popular music in a manner that would become increasingly widespread in the United States and beyond only fifty years or so later. In the 1850s and '60s Sax, Berlioz, and others were striving in Paris to habilitate the saxophone within those classical music contexts that they saw as providing its ultimate legitimation. In contrast, Soualle's proto-vaudevillian performances were already outlining an alternative and more populist future for an instrument upon which would be conferred, in the first decades of the twentieth century, a musical identity largely predicated on its use in very similar contexts. Unfortunately, Sax's death in 1894, followed by Soualle's own just five years later, meant that neither would live quite long enough to see this happen.

91. By 1881 Lecomte was employing around 115 people making brass instruments in a steam-powered factory. See William Waterhouse, *The New Langwill Index: A Dictionary of Musical Wind-Instrument Makers and Inventors* (London: Tony Bingham, 1993), 229.